



ProteShea

Learn. Apply. Create™

FuelCan™-910

Development Case

ECCN (US): EAR99



USER MANUAL

FuelCan



Fuel Your Creativity

Use of this product or documentation signifies acceptance of the legal terms and conditions set forth below. Disagreement with any part of the legal terms and conditions set forth below permits the return of this product within 30-days of the date of purchase, per the terms described below.

Website: <https://proteshea.com>

Phone: 772-336-9761

REVISION HISTORY



Date	Version	Revision
4/15/2019	1.0	Initial release
5/16/2019	1.1	Modified “Intended Uses” section and corrected page numbers
5/25/2019	1.2	Modified Section B. #4
6/29/2019	1.3	Added clause to INTELLECTUAL PROPERTY in Section O. Added development boards to Section C. Added Fig. 8.

Table of Contents

SYMBOL DESCRIPTION	page 4
IMPORTANT INSTRUCTIONS & SAFETY	page 5
INTENDED USES	page 6
FEATURES	page 7
TECHNICAL SPECIFICATIONS	page 8
DESCRIPTION OF PRODUCT	page 9
HOW TO USE PRODUCT	page 10
INSTALLATION	page 18
OPERATION	page 19
MAINTENANCE	page 20
TROUBLESHOOTING	page 20
REPAIR INFORMATION	page 21
INDEX	page 23
CONTACT INFORMATION	page 24
WARRANTY INFORMATION	page 25
LEGAL TERMS AND CONDITIONS	page 25

A. SYMBOL DESCRIPTION

Table 1. Symbol Description.

Symbol	Warning Description
 ELECTRIC SHOCK WARNING	Symbol draws your attention to potential serious injury or death due to electric shock
 WARNING	Symbol draws your attention to potential serious or minor injury
 ESD CAUTION	Symbol draws your attention to notification that the device is sensitive to electro-static discharge (ESD). Handle electronics on an ESD workbench and wear proper protection and clothing to prevent accidental damage or loss of functionality.



WARNING: To prevent injury, death, and/or damage to property while using this product, read this **entire** instruction manual.

B. IMPORTANT INSTRUCTIONS & SAFETY

WHEN USING THIS PRODUCT, BASIC PRECAUTIONS SHOULD ALWAYS BE FOLLOWED TO REDUCE THE RISK OF FIRE, ELECTRIC SHOCK, DAMAGE TO PROPERTY, AND/OR INJURY TO PERSONS, INCLUDING THE FOLLOWING:

1. Read all instructions before using the FuelCan.
2. Use the FuelCan only as described in this manual. Any other use not recommended by ProteShea may cause, without limitation, fire, electric shock, damage to property, and/or injury to persons.
3. Do not modify the FuelCan in any way that is not described in this user manual.
4. Do not operate the FuelCan in a wet environment.
5. Do not operate the FuelCan after it malfunctions. Disconnect power at the main 5-pin DIN connector and unplug the AC/DC power supply from the AC source.
6. To prevent a possible fire, do not operate the FuelCan with lid closed without proper ventilation, heat-syncing, and/or cooling.
7. Consult a qualified electrician for use of chassis ground (shield) connection to earth ground.
8. Do not allow foreign objects underneath the panel subassembly opening as this may pose an electric shock warning or short-circuits.
9. The top and bottom panel subassemblies may have sharp edges, use caution to reduce the risk of injury.
10. Use caution and do not use FuelCan if the acrylic becomes cracked or broken as the sharp edges may increase risk of injury. See the **REPAIR INFORMATION** section if acrylic is damaged.
11. The FuelCan contains small parts which pose a choking hazard, keep out of the reach of children less than 6 years of age.
12. When installing development boards or other electronics, see the **INSTALLATION** section for additional warnings and precautions.
13. For safe operation throughout the lifetime of this product, see the **MAINTENANCE** section.

C. INTENDED USES

The FuelCan enables rapid prototyping and ease of system design by offering a unique one-fits-all solution for development boards that have an area of less than 15 square inches, where one dimension does not exceed 4 inches. Its intended to provide a low cost and reusable platform for design in high school, university lab coursework, and research.

Custom printed-circuit boards (PCBs) can be designed to plug into the 4x26-pin connector which can include sensors, instrument modules, or solderable breadboards. The AC-DC power supply provides increased power ratings and four voltage outputs that make it more versatile than stand-alone development boards.

Its intended users, 12+ years of age, include the following:

- High school students interested in a STEM degree
- College students pursuing a STEM degree
- University researchers

Its intended use cases include the following:

- Prototyping with
 - Raspberry Pi
 - Arduino™
 - PYNQ™-Z1, ARTY™, and BASYS™ development boards
- Teaching electronic circuit analysis
- Teaching computer programming
- Teaching robotic motor control and control theory
- Teaching digital signal processing concepts
- Teaching communication interfaces to sensors
- Teaching high-speed circuit board design and analysis
- Network of FuelCans for teaching distributed computing

D. FEATURES

FuelCan development platform contains:

- Rugged Nanuk 910 case
- Cable and parts storage compartment (top panel subassembly)
- 4 hold-down clamps to secure development board
- AC-DC Adapter and outlet plug
- Bottom panel subassembly
- External connectors for isolated USB and ethernet
- 2 banana plug to mini-grabber cables
- 4x26-pin high-density connector
- +12V0, -12V0, +5V0, and +3V3 DC voltage rails via banana jacks
- 6' Type A to Type A USB cable
- 1' Type A to micro USB cable
- 1' Type A to Type B USB cable
- 3/32" hex driver
- Documentation: User Manual

E. TECHNICAL SPECIFICATIONS

Table 2. Overview of Technical Specification.

Model	FuelCan-910
Mass (lbs)	5.0
External Dimensions (L x W x H)	14.3" x 11.1" x 4.7"
Prototyping Area Dimensions	7.0" x 4.0"
AC-DC Adapter	90 - 120VAC
AC-DC Adapter Rated Power	28W
Operating Temperature	0-85 °C
+12.0VDC Supply Current Rating	1A
-12.0VDC Supply Current Rating	0.3A
+5.0VDC Supply Current Rating	2.5A
+3.3VDC Supply Current Rating	2.5A
Max Current Rating of 4x26-pin Connector	5.7A



WARNING: To prevent risk of fire or damage, do not exceed maximum current or power ratings for the AC-DC adapter.



WARNING: Combined current rating for the +5.0V and +3.3V supplies is 2.5A. Potential risk of fire, damage, or injury if this rating is exceeded. Ensure that these limits are not exceeded across the entire application including development board and full Canister board stack.

NOTE: Please see <https://www.meanwell.com/webapp/product/search.aspx?prod=GP25A> for additional details about the AC-DC Adapter.

F. DESCRIPTION OF PRODUCT

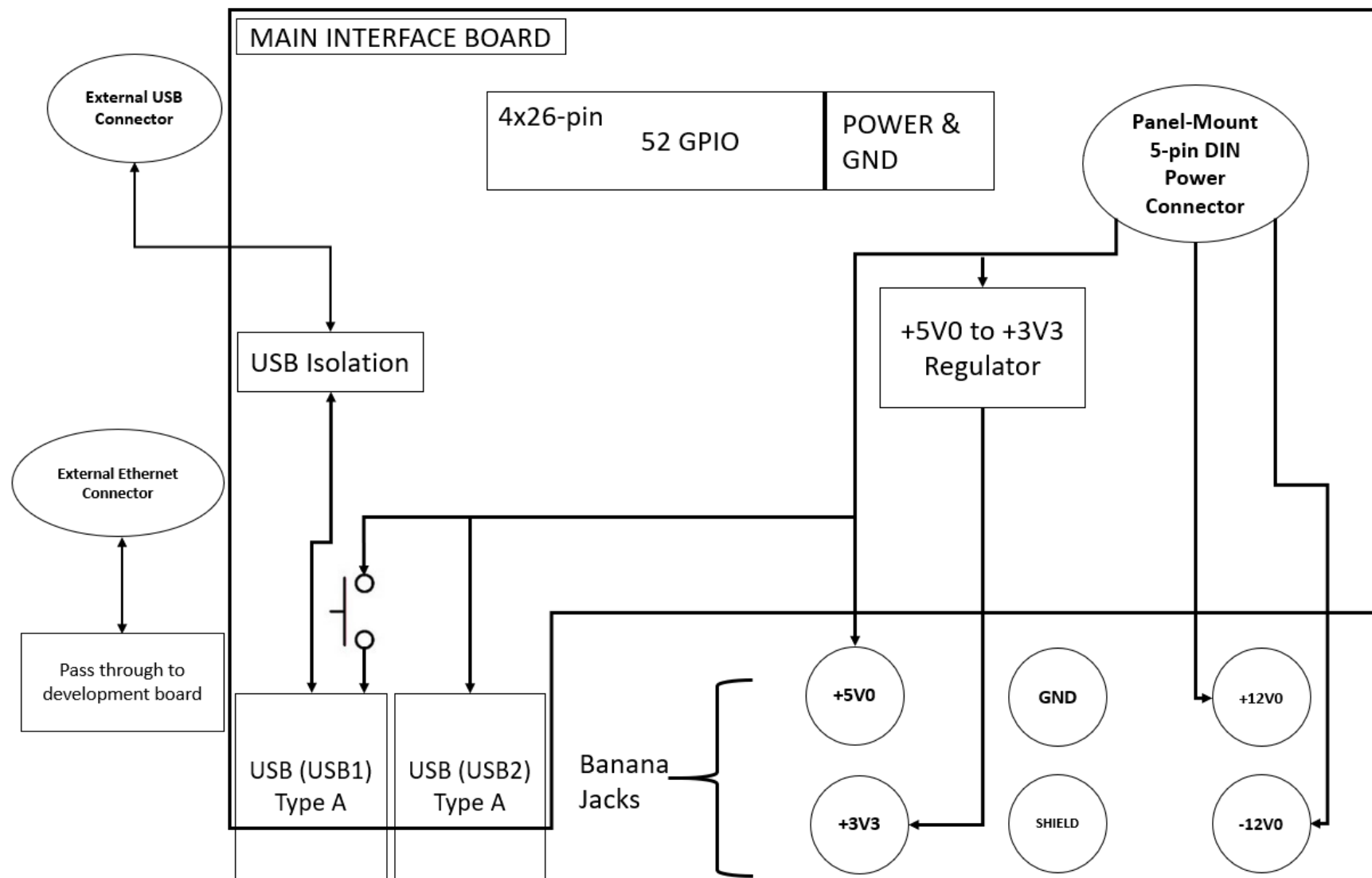

Figure 1. FuelCan Block Diagram.

G. HOW TO USE PRODUCT

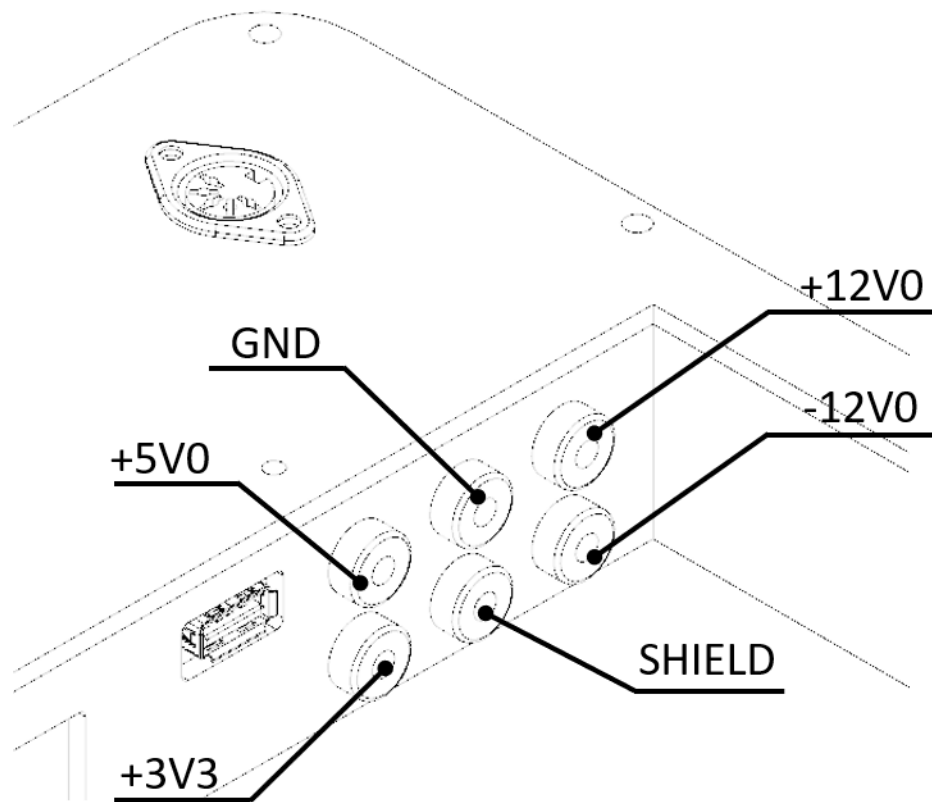

Figure 2. Banana Jack Orientation on Bottom Panel Subassembly.

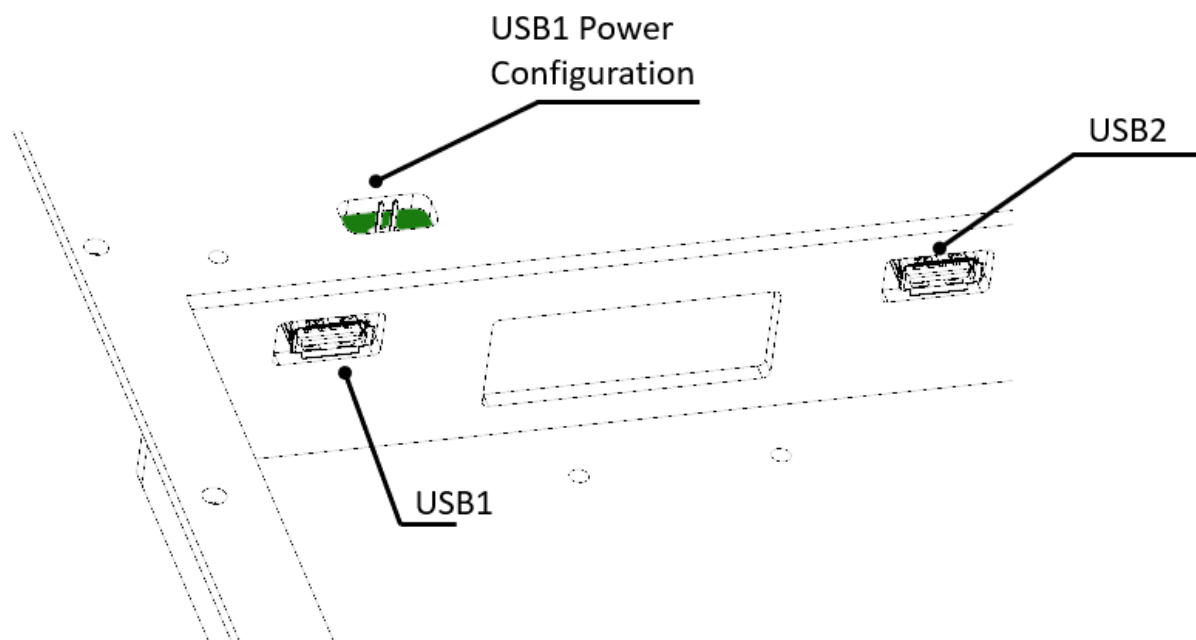

Figure 3. USB Connectors on Bottom Panel Subassembly.



WARNING: Always double-check your development boards power direction (input vs. output) to avoid power conflicts that may result in damage or fire.

The USB1 connector provides USB isolation for preventing ground loops with an optional fuse jumper to provide +5V0 output to your host. The USB2 connector provides +5V0 output for any device requiring power via USB cable.

Table 3. USB1 Jumper Configuration.

Description	Fuse Jumper
+5V0 Enabled to USB1	Inserted
+5V0 Disabled to USB1	Removed

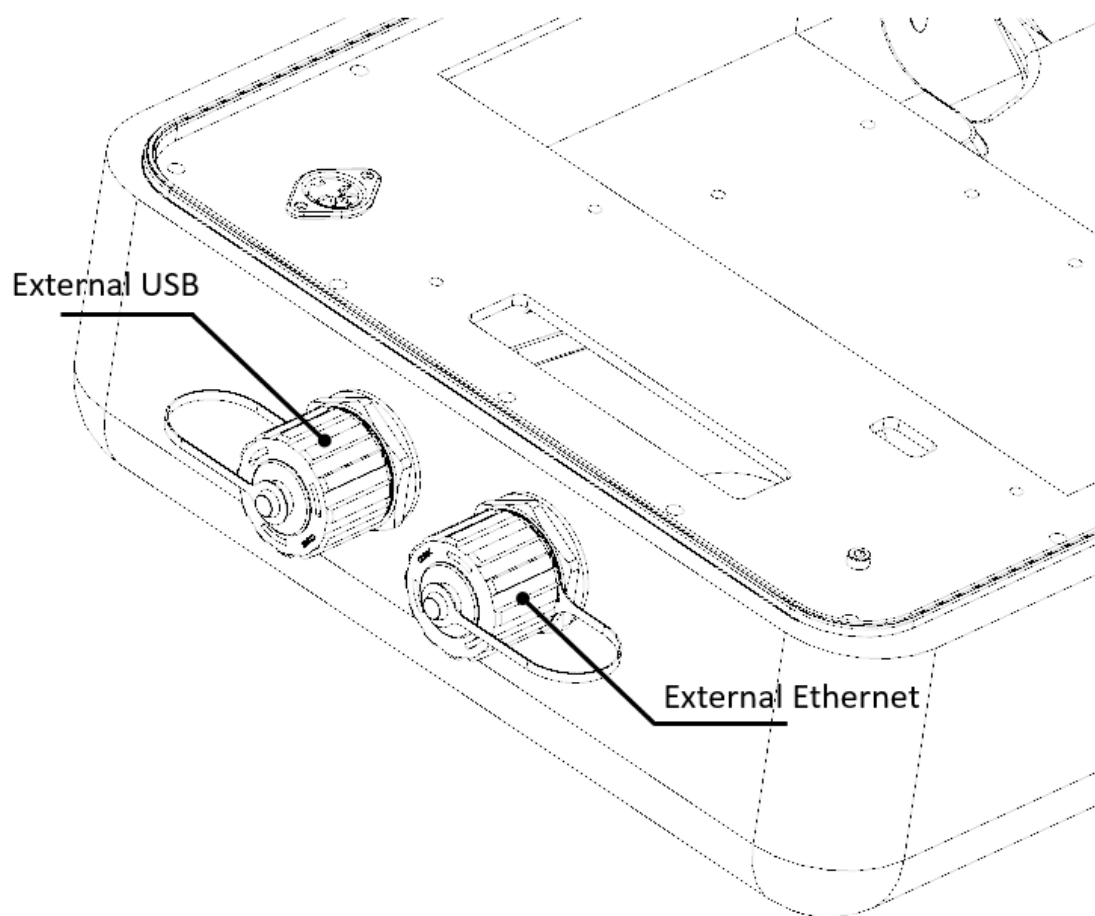

Figure 4. External Connector Placement.

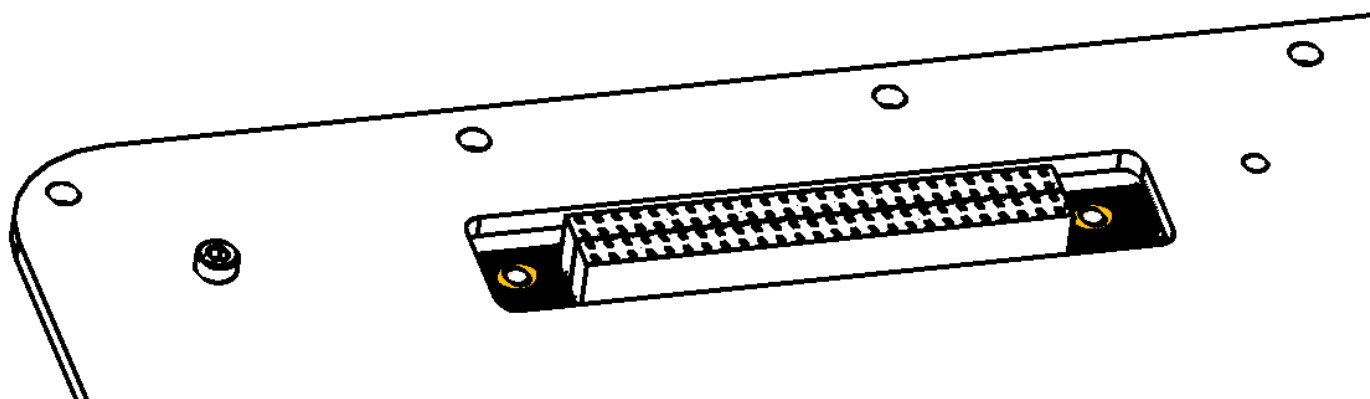

Figure 5. 4x26-pin Connector.

Table 4. Pinout for 4x26-pin Connector.

	1	2	3	4	5	6	7	8	9	10	11	12	13
D	GPIO-D01	GPIO-D02	GPIO-D03	GPIO-D04	GPIO-D05	GPIO-D06	GPIO-D07	GPIO-D08	GPIO-D09	GPIO-D10	GPIO-D11	GPIO-D12	GPIO-D13
C	GPIO-C01	GND	GPIO-C03	GND	GPIO-C05	GND	GPIO-C07	GND	GPIO-C09	GND	GPIO-C11	GND	GPIO-C13
B	GND	GPIO-B02	GND	GPIO-B04	GND	GPIO-B06	GND	GPIO-B08	GND	GPIO-B10	GND	GPIO-B12	GND
A	GPIO-A01	GPIO-A02	GPIO-A03	GPIO-A04	GPIO-A05	GPIO-A06	GPIO-A07	GPIO-A08	GPIO-A09	GPIO-A10	GPIO-A11	GPIO-A12	GPIO-A13

	14	15	16	17	18	19	20	21	22	23	24	25	26
GPIO-D14	GPIO-D15	GPIO-D16	GPIO-D17	GPIO-D18	GND	+5V0	GND	+3V3	GND	+12V0	GND	-12V0	
GND	GPIO-C15	GND	GPIO-C17	GPIO-C18	GND	+5V0	GND	+3V3	GND	+12V0	GND	-12V0	
GPIO-B14	GND	GPIO-B16	GND	GPIO-B18	GND	+5V0	GND	+3V3	GND	+12V0	GND	-12V0	
GPIO-A14	GPIO-A15	GPIO-A16	GPIO-A17	GPIO-A18	GND	+5V0	GND	+3V3	GND	+12V0	GND	-12V0	

There are multiple orientations of the hold-down clamps that can be used to secure your development board. Start by placing the development board inside the heat-set insert box in the prototyping area as shown in Fig. 6. Arrange the board in a manner that will allow the easiest connections to the various power supply jacks, USB, and/or ethernet connectors. Once you are satisfied with the orientation, screw down (hand tighten) the hold-down clamps into any four of the heat-set inserts (circled in Fig. 6) to secure the edges of the development board. An example configuration is shown in Fig. 7 and Fig. 8. At least two to four hold-down clamps shall be used to safely secure the development board. The holes for threaded insert locations may vary.

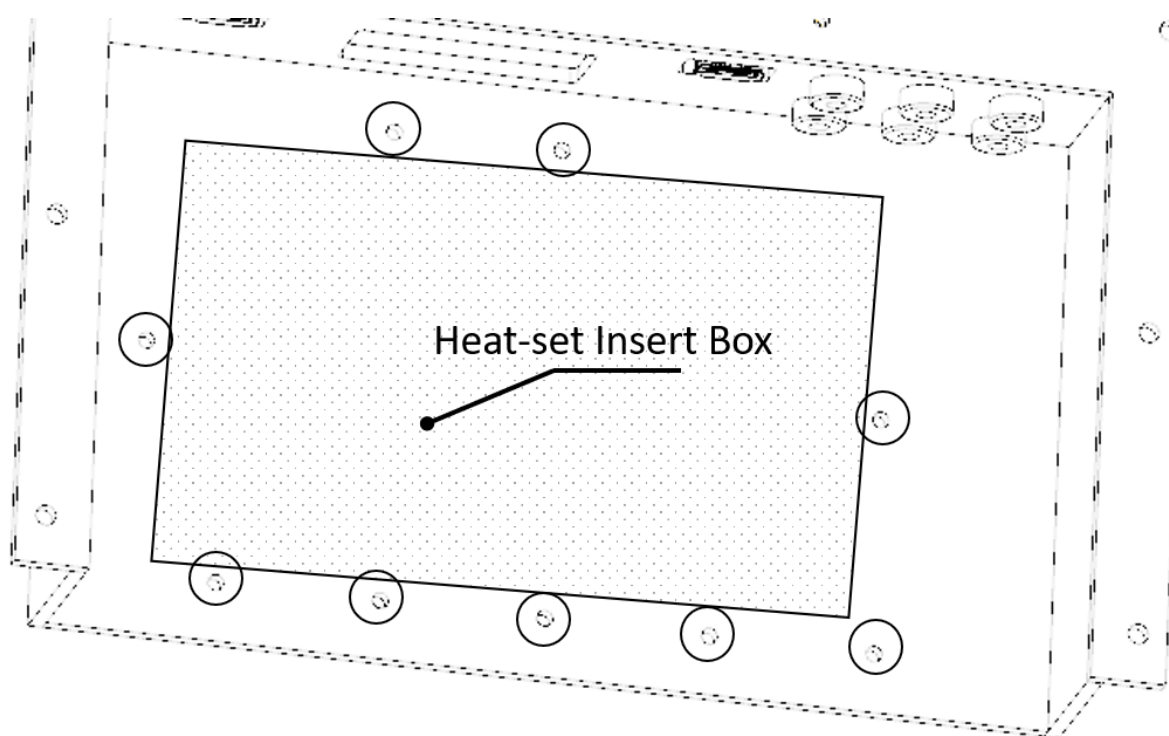

Figure 6. Heat-set Insert Box.

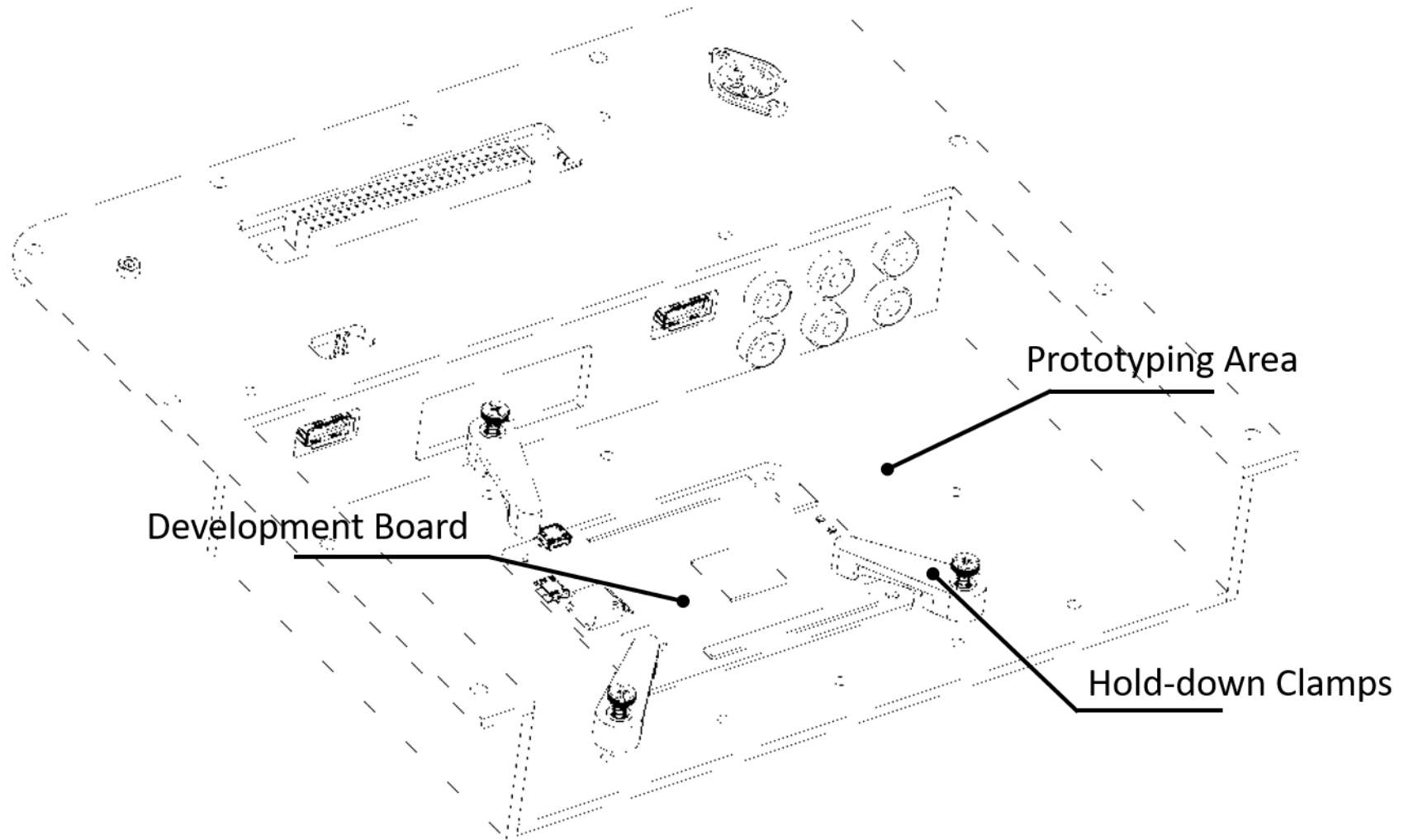

Figure 7. Development Board Placement on Prototyping Area.

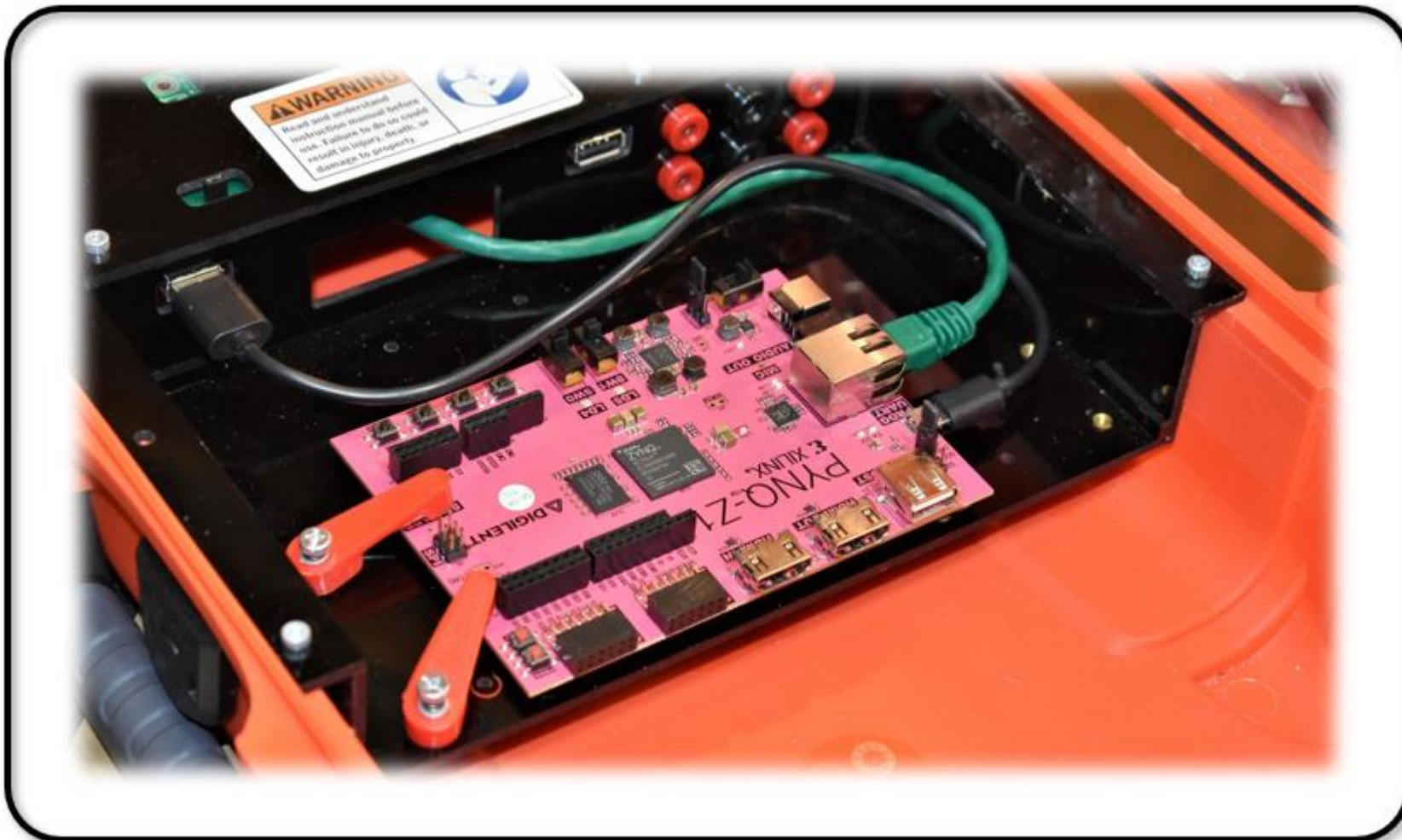

Figure 8. Mounting PYNQ™-Z1 with Hold-Down Clamps.



WARNING: Using excessive force when plugging in a Canister could crack or damage the acrylic subassembly. Use caution to prevent potential injury from cracked or damaged acrylic.



ELECTRIC SHOCK WARNING: Plugging in the Canister improperly could pose a potential risk of fire, damage, electric shock, or injury.

The FuelCan's 4x26-pin header is compatible with the Canister line of products. Please review the user manuals for the Canisters for instructions on safety, installation, operation, and maintenance.

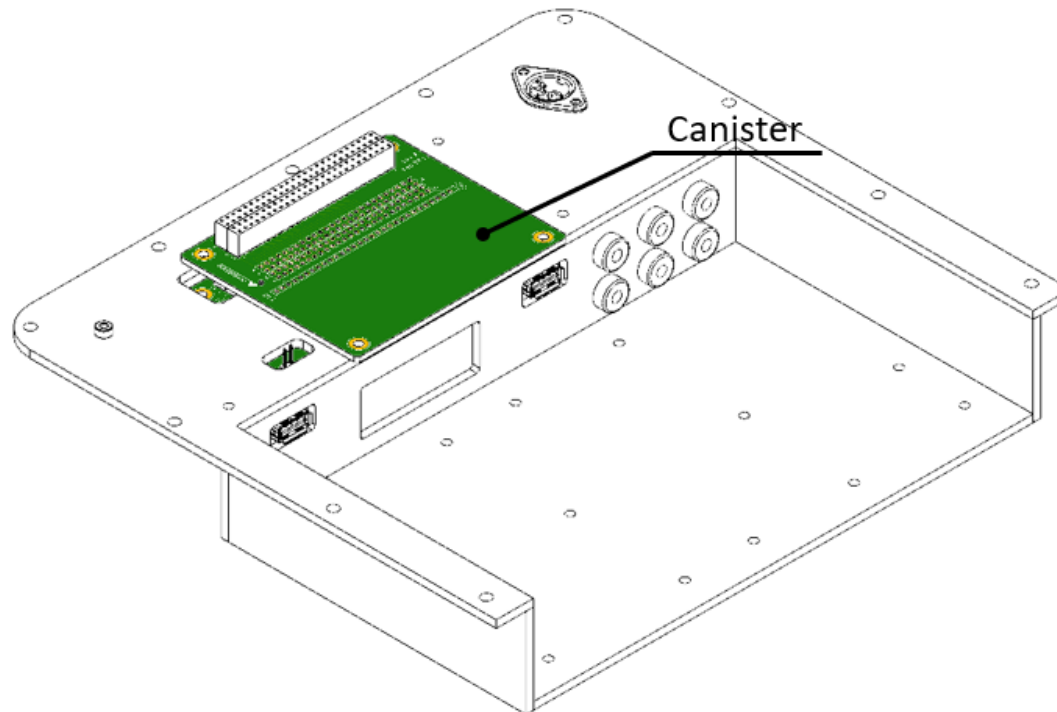

Figure 9. Canister Compatibility.

H. INSTALLATION

Visit us at <https://proteshea.com/fuelcan> to find up-to-date information and how-to videos for the FuelCan.

Follow the steps below for first-time operation of the FuelCan:



ELECTRIC SHOCK WARNING: Never use the FuelCan with a damaged AC-DC Adapter or power outlet cable. There is a potential danger of fatal electric shock.



ESD CAUTION

1. Inspect AC-DC Adapter and power cables to ensure there are no cuts, defects, or other damages. Do not proceed if any damage is found and see **REPAIR INFORMATION**.
2. Please see https://www.nanuk.com/docs/NANUK_Warranty%20Booklet.pdf for instruction on opening the latches.
3. Inspect top and bottom panel assemblies for possible damage from shipping. Do not proceed if any damage is found and see **REPAIR INFORMATION**.
4. Ensure the case is open and in a dry, well-ventilated area.
5. Remove the acrylic divider panel to allow for external cable connections to the development platform.
6. Install desired development board using the supplied hold-down clamps – see **HOW TO USE PRODUCT** section.
7. Plug the 5-pin DIN connector (male receptacle) from the AC-DC Adapter into the 5-pin DIN connector (female socket) on the bottom panel subassembly shown in Fig. 10. The 5-pin connector is keyed so it only fits one way.
8. Plug the AC power cable from the AC-DC Adapter to an AC outlet.

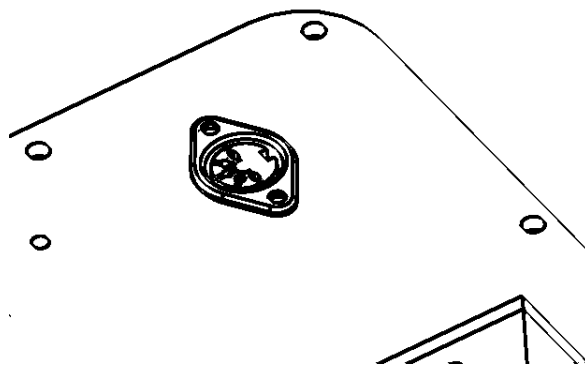

Figure 10. 5-pin DIN Connector.

I. OPERATION

Follow the steps below for operation of the FuelCan:



ELECTRIC SHOCK WARNING: Never use the FuelCan with a damaged AC-DC Adapter or power cable. There is a potential danger of fatal electric shock.



ESD CAUTION

1. Inspect the AC-DC Adapter and power cables to ensure there are no cuts, defects, or other damages. Do not proceed if any damage is found and see **REPAIR INFORMATION**.
2. Inspect the acrylic subassemblies on the FuelCan to ensure there are no cracks or other damage. Do not proceed if any damage is found and see **REPAIR INFORMATION**.
3. Ensure the case is open and in a dry, well-ventilated area.
4. Remove the acrylic divider to allow for external cable connections to the development platform.
5. Install desired development board using the supplied hold-down clamps – see **HOW TO USE PRODUCT** section.
6. Plug the 5-pin DIN connector (male receptacle) from AC-DC Adapter into the 5-pin DIN connector (female socket) on the panel subassembly.
7. Plug AC power cable from AC-DC Adapter into AC outlet.

Follow the steps below for replacing the development board:



ELECTRIC SHOCK WARNING: Always disconnect power to the bottom panel subassembly before replacing the development board to prevent injury from electric shock.



ESD CAUTION

1. Disconnect power from bottom panel subassembly.
2. Unscrew hold-down clamps and set aside.
3. Remove development platform.
4. Place new development platform on the prototyping area and secure with hold-down clamps.
5. Plug in 5-pin DIN power connector to panel subassembly.

J. MAINTENANCE

To ensure the longevity of your FuelCan, take proper precautions as listed below:

- Store loose parts in cable storage compartment.
- Keep box clean from dust and other debris.
- Clean any moisture build-up inside the FuelCan.
- Replace panel subassemblies if cracked or damaged – see **REPAIR INFORMATION** section.
- Store the FuelCan in a cool, dry place.
- Use only for intended purposes – see **INTENDED USES** section.

K. TROUBLESHOOTING

Table 5. Troubleshooting Solutions.



Problem	Cause	Solution
USB isolator is not functioning	Not using USB device that is USB 2.0 compliant	Only use USB 2.0 compliant devices
Power supplies are not outputting the correct voltage	Loose soldering joint to DIN connector or banana jacks	With device powered on, probe voltage rails with multimeter to check output voltages. If unexpected voltages are measured, see REPAIR INFORMATION section.
	AC-DC adapter is malfunctioning	Replace AC-DC adapter



L. REPAIR INFORMATION

Please email support@proteshea.com for questions about repairs. If a repair needs to be made within 30 days of purchase, see the **LEGAL TERMS AND CONDITIONS** section for warranty information.

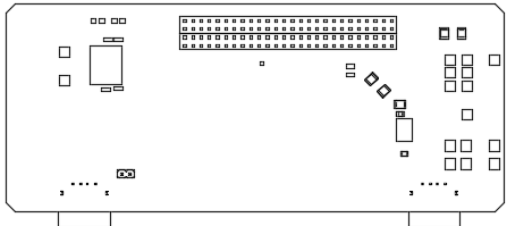
If a repair claim is made outside of the valid warranty period, please email support@proteshea.com for further instructions. Only have your FuelCan repaired by ProteShea.

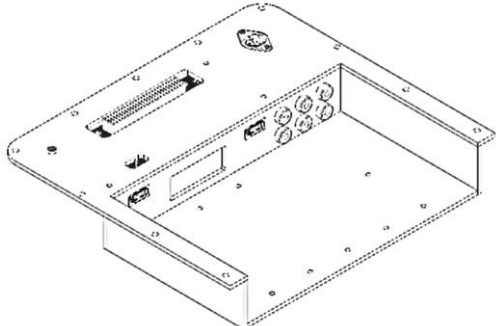
Table 6. Components of FuelCan.

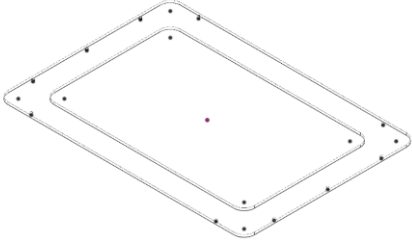
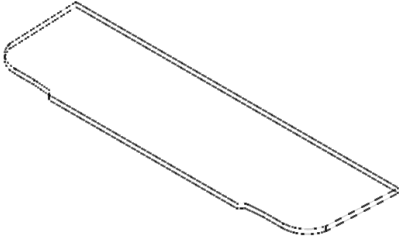
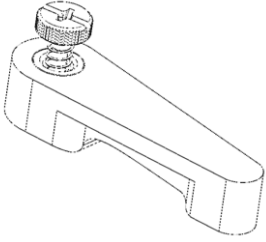
<p>Main Interface Board</p>	
<p>Meanwell AC-DC Adapter</p>	
<p>Nanuk 910 Case</p>	
<p>Bottom Panel Subassembly</p>	

<p>Top Panel Subassembly</p>	
<p>Divider Panel</p>	
<p>Hold-down clamps</p>	
<p>External USB Connector</p>	
<p>External Ethernet Connector</p>	

M. INDEX**A**

AC-DC adapter	pg 21
Address	pg 24

B

Banana jack connectors	pg 10
------------------------	-------

C

Connector (4x26-pin)	
Pinout	pg 13
Orientation	pg 13
Contact details	pg 24
Customer support	pg 24

D

Dimensions	pg 8
DIN connector	pg 18

E

Earth ground	pg 10
ESD caution	pg 5
External ethernet connector	pg 12
External USB connector	pg 12

F

Features	pg 7
First time use	pg 18
FuelCan	
How to use	pg 10
Support	pg 24
Website	pg 24

G

Ground	pg 10
--------	-------

H

Heat-set inserts	pg 14
------------------	-------

I

Installation	pg 18
Intended uses	pg 6

L

Legal information	pg 25
-------------------	-------

M

Main interface board	pg 21
Maintenance	pg 20
Mass	pg 8

N

Nanuk case	pg 21
------------	-------

P

Phone	pg 24
Power configuration	pg 10

R

Rated power	pg 8
Repair information	pg 21

S

Safety	pg 5
Symbol description	pg 4
System overview	pg 9

T

Technical specifications	pg 8
Terms and conditions	pg 25
Troubleshooting	pg 20

U

USB connectors	pg 11
----------------	-------

W

Website	pg 24
---------	-------

N. CONTACT INFORMATION

ProteShea LLC
290 NW Peacock Blvd #880143
Port Saint Lucie, FL 34988

Phone: 772-336-9761

Please send us your feedback and/or concerns by visiting <https://proteshea.com/contact/> or via email at support@proteshea.com

O. LEGAL TERMS AND CONDITIONS

USE OF THE PRODUCT OR DOCUMENTATION FOR THE FUEL CAN-910 (“FUEL CAN”) SIGNIFIES ACCEPTANCE OF THE LEGAL TERMS AND CONDITIONS (“AGREEMENT”) SET FORTH BELOW. THE FUEL CAN IS PROVIDED ON AN “AS IS” AND “AS AVAILABLE” BASIS. PROTESHEA HAS THE RIGHT TO CHANGE OR DISCONTINUE THE FUEL CAN AT ANY TIME WITHOUT NOTICE. PROTESHEA HAS THE RIGHT TO CHANGE, REVISE, OR MODIFY THE AGREEMENT AT ANY TIME AND WITHOUT NOTICE TO THE CUSTOMER. THE DIAGRAMS USED IN THIS USER MANUAL MAY VARY WITH THE FUEL CAN.

THE FUEL CAN IS TO BE USED ONLY FOR THE INTENDED USES SPECIFIED IN THIS MANUAL AND PROTESHEA ASSUMES NO LIABILITY FOR CHANGES OR MODIFICATIONS THAT THE CUSTOMER CHOOSES TO MAKE TO THE FUEL CAN. THE CUSTOMER ASSUMES FULL RESPONSIBILITY FOR ENSURING THAT ANY DESIGN INVOLVING THE USE OF THE FUEL CAN IS IN COMPLIANCE WITH ALL LAWS AND REGULATIONS FOR THE FREQUENCY AND POWER LEVELS OF, INCLUDING, WITHOUT LIMITATION, RADIO FREQUENCY DEVICES, WHETHER INTENTIONAL OR UNINTENTIONAL. THE CUSTOMER SHALL NOT TRANSFER, SELL, DISTRIBUTE, OR EXPORT THE FUEL CAN TO ANY OTHER THIRD PARTY OR COUNTRY WITHOUT THE PRIOR WRITTEN CONSENT OF PROTESHEA. THE CUSTOMER ACKNOWLEDGES THAT THE FUEL CAN IS CLASSIFIED AS EAR99 AND WILL COMPLY WITH THE RULES AND REGULATIONS RELATING TO UNITED STATES EXPORTS.

WARRANTY INFORMATION. ProteShea warrants that the FuelCan accompanying this document will be free from manufacturing defects for up to 30 days from the date of purchase, subject to the terms and conditions of this Limited Warranty (“THE WARRANTY”). In the event of a warranty claim, customer shall pay for the shipping costs both to and from ProteShea. Customer assumes full liability for loss and/or damage to the FuelCan during the warranty claim.

LIMITATION OF WARRANTY. The warranty set forth below, applies only to the original customer and is based solely on the judgment and discretion of ProteShea. The warranty does not cover the Nanuk Case, AC-DC Adapter, nor external connectors. ProteShea shall not be liable and this warranty shall not apply if any defects or damages are caused by or result from, without limitation, modifications to the FuelCan by anyone other than ProteShea, natural breakdown of colors and material over time, normal wear and tear, accident, abuse, mishandling, or irresponsible use of the FuelCan. PROTESHEA SPECIFICALLY DISCLAIMS THE WARRANTY FOUND IN UCC SECTION 2-312(3) THAT THE FUEL CAN SHALL BE DELIVERED FREE OF THE RIGHTFUL CLAIM OF ANY THIRD PERSON BY WAY OF INFRINGEMENT. EXCEPT FOR THE EXPRESSED WARRANTY SET FORTH IN THIS AGREEMENT, PROTESHEA DISCLAIMS ANY AND ALL OTHER EXPRESSED OR IMPLIED WARRANTIES, INCLUDING, WITHOUT LIMITATION, WARRANTIES OF MERCHANTABILITY OR FITNESS FOR A PARTICULAR PURPOSE, WHETHER WRITTEN OR ORAL.

LIMITATION OF LIABILITY. ProteShea’s aggregate liability for any and all causes relating to the use or possession of the FuelCan, regardless of the form of the claim, shall be limited to the sum of \$100 US dollars, whether arising out of negligence, tort, strict liability, contract, breach of

agreement, or otherwise. IN NO EVENT SHALL PROTESHEA BE LIABLE FOR—AND THE CUSTOMER OR ANY OTHER PARTY SHALL NOT BE ENTITLED TO—CONSEQUENTIAL, COMPENSATORY, EXEMPLARY, SPECIAL, PUNITIVE, INCIDENTAL, DIRECT, OR INDIRECT DAMAGES ARISING OUT OF THE USE OR POSSESSION OF THE FUEL CAN, INCLUDING, WITHOUT LIMITATION, THE VALUE OF THE CONTENTS OF THE FUEL CAN, INJURY, LOST PROFITS OR REVENUE, LOSS OF EQUIPMENT, OR OTHER COMMERCIAL OR ECONOMIC LOSS, WHETHER OR NOT THE POSSIBILITY OF SUCH LOSSES OR DAMAGES HAS BEEN DISCLOSED TO PROTESHEA. IF CUSTOMER DECIDES TO BUILD THEIR OWN PRINTED CIRCUIT BOARDS WITH 4X26 CONNECTOR TO BE COMPATIBLE FOR THE FUEL CAN, CUSTOMER ACKNOWLEDGES AND AGREES THAT THEY WILL NOT HOLD PROTESHEA LIABLE FOR, WITHOUT LIMITATION, ANY DAMAGES, LOST PROFITS OR REVENUE, OR INJURY.

LIMITATION OF DAMAGES. ProteShea’s aggregate liability for any and all damages to the customer resulting from the use or possession of the FuelCan shall not exceed the sum of \$100 US dollars regardless of whether the claim giving rise to such damages is based upon negligence, tort, strict liability, contract, or otherwise.

INTELLECTUAL PROPERTY. All product names, trademarks, logos, and trade names (“MARKS”) appearing in the FuelCan are the properties of their respective owners. Use of these marks does not imply endorsement. ProteShea marks are registered trademarks of ProteShea LLC and may not be used without the prior written consent of ProteShea.

Raspberry Pi is a trademark of the Raspberry Pi Foundation.

PYNQ™, ARTY™, and BASYS™ are trademarks of National Instruments. Neither ProteShea, nor any software programs or other goods or services offered by ProteShea, are affiliated with, endorsed by, or sponsored by National Instruments.

COPYRIGHT. The user manual contains information which is protected by copyright. It is not permitted to copy, photocopy, distribute, modify, reproduce, retransmit, or upload this user manual for use or translate them into another language without the prior written consent of ProteShea.

INDEMNIFICATION. Customer acknowledges and agrees that they are personally responsible for their conduct while using the FuelCan. Customer agrees to indemnify, defend and hold harmless ProteShea, its owners, directors, officers, agents, and employees from and against all claims, losses, expenses, damages and costs, and reasonable attorney’s fees, resulting from or arising out of customer use, misuse, negligence, or inability to use the FuelCan. This indemnification includes disputes between third parties against ProteShea, as well as disputes between ProteShea and Customer, resulting from or arising out of customer use, misuse, negligence, or inability to use the FuelCan.

GOVERNING LAW, VENUE, JURISDICTION. The laws of the State of New York will govern this Agreement without regard to principles of conflicts of laws. Customer agrees that any disputes or claims that customer may have against ProteShea, which are not subject to the arbitration

clause described below, will be resolved by the state and federal courts in the County of Saint Lucie, Florida. Customer hereby agrees to personal jurisdiction in the County of Saint Lucie, Florida. Customer agrees, in the event that any dispute arises with ProteShea, at least 30-days prior to filing any action or demanding arbitration, Customer will provide written notice to ProteShea of the dispute, and attempt to negotiate a written resolution of the matter that will be agreed upon by all parties involved. In any dispute, the terms of this agreement will control.

ARBITRATION. ANY AND ALL CLAIMS OR DISPUTES BETWEEN PROTESHEA AND CUSTOMER RELATING IN ANY WAY TO THESE TERMS OR THE SERVICES OR PRODUCTS (INCLUDING BUT NOT LIMITED TO THE FUELCAN) PROVIDED BY PROTESHEA MUST BE RESOLVED IN BINDING ARBITRATION RATHER THAN IN COURT. IN ARBITRATION, THERE IS NO JUDGE OR JURY, AND COURT REVIEW OF AN ARBITRATION AWARD IS LIMITED. THE ARBITRATOR CAN AWARD ANY DAMAGES OR RELIEF ON YOUR INDIVIDUAL CLAIM THAT A COURT OF LAW COULD, INCLUDING INDIVIDUAL INJUNCTIVE RELIEF AND ATTORNEYS' FEES WHEN AVAILABLE UNDER THE GOVERNING LAW. ALL ARBITRATIONS WILL BE CONDUCTED ON AN INDIVIDUAL BASIS, AND THERE SHALL BE NO CLASS ACTIONS IN ARBITRATION. CUSTOMER AGREES THAT ANY ARBITRATION WILL OCCUR IN THE COUNTY OF SAINT LUCIE, FLORIDA.